

IQ EV Charger 2

Quick install guide

Scan for the latest guide

Scannen Sie nach dem neuesten
Leitfaden

Scannez pour le dernier guide

Scan naar de nieuwste handleiding

Escanea para el último guía

Nuskaitykite naujausią gidą



MODEL

IQ-EVSE-EU-3032-0005-1300

IQ-EVSE-EU-3032-0105-1300

VERSION 1.0

NOVEMBER 2024



140-00515-01

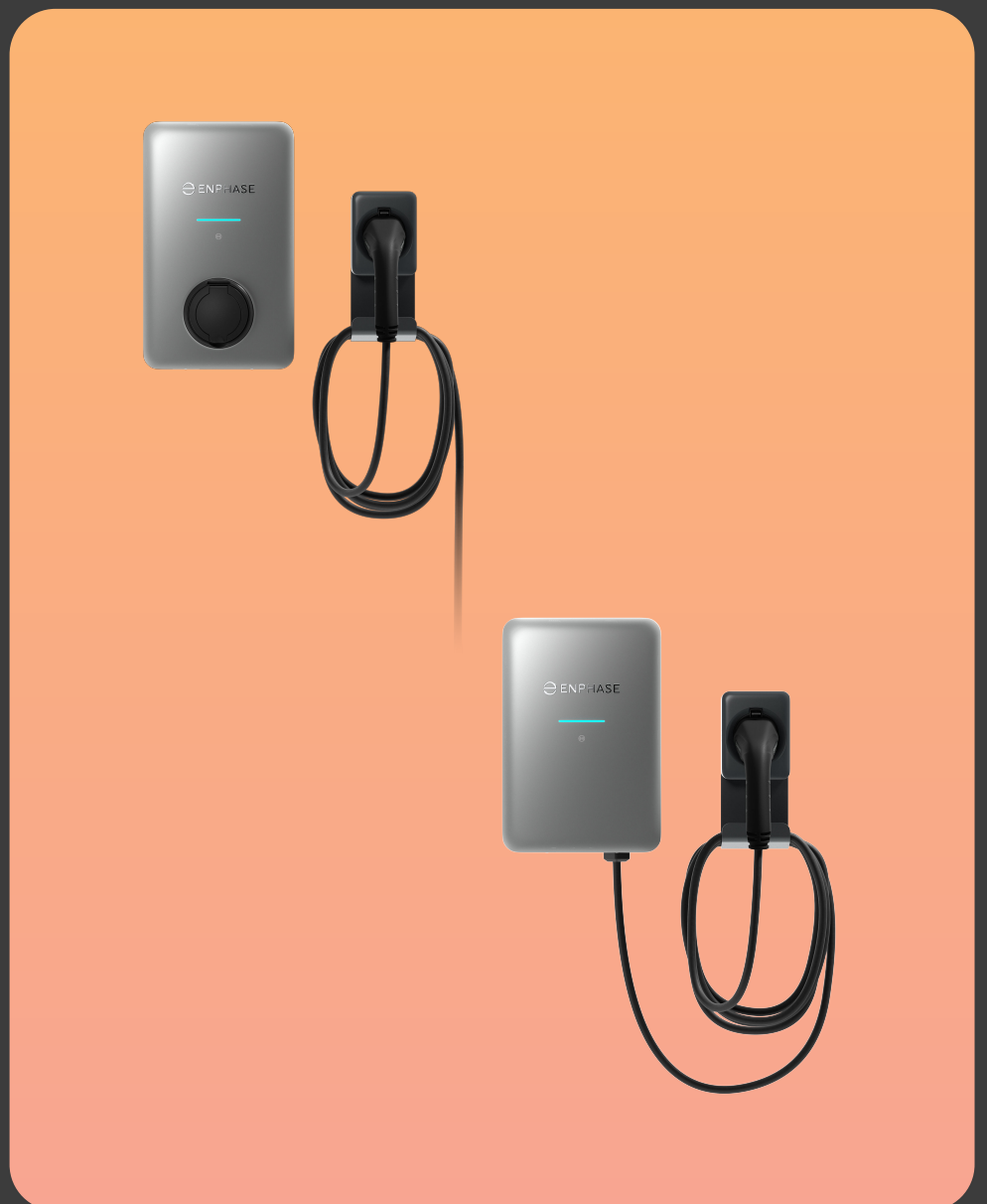

This page is left blank intentionally.

Contents

1. Introduction	5
2. Integration with the Enphase Energy System	5
3. Pre-installation checklist	6
4. What's in the box	7
4.1. Tethered Type-2 model	7
4.2. Socketed Type-2 model	8
5. Tools/Additional items required	8
6. Mounting the wall bracket	9
6.1. Mounting on a timber or concrete wall	9
6.2. Mounting on a single vertical timber stud	10
7. Wall-mounting the IQ EV Charger 2	10
8. Mounting the connector holster	12
9. Power supply wiring	12
9.1. Supply wiring for tethered Type-2 model	13
9.1.1. Preparation	13
9.1.2. Supply wiring through the rear cable entry	13
9.1.3. Supply wiring through the bottom cable entry	14
9.1.4. Completing supply wiring	15
9.2. Supply wiring for socketed Type-2 model	15
9.2.1. Preparation	15
9.2.2. Supply wiring through the rear cable entry	16
9.2.3. Supply wiring through the bottom cable entry	16
9.2.4. Completing the supply wiring	17
9.3. Phase wiring diagrams for grid supply types	18
9.3.1. Grid supply with a TN or TT earthing (with neutral)	18
9.3.2. Grid supply with an IT earthing (without neutral)	20
10. Wiring connections for communication	20
10.1. Communication cable wiring through the rear cable entry	21
10.1.1. Tethered Type-2 model	21

10.1.2. Socketed Type-2 model	21
10.2. Communication cable wiring through the bottom entry	22
10.2.1. Tethered Type-2 model	22
10.2.2. Socketed Type-2 model	23
11. Activating the IQ EV Charger 2	23
11.1. Activation through the Enphase Installer App	24
11.2. Activation through the Enphase App	24
12. Finishing the installation	24
13. Post-installation checklist	24
14. Troubleshooting	25
14.1. MID meter display	25
14.2. LED pattern of an uncommissioned device	25
14.3. LED pattern of an activated device	25
15. Accessories	26
16. Specifications	26
17. Safety information	27
Corporate headquarters contact information	29
Revision history	29

1. Introduction

The IQ EV Charger 2 combines advanced hardware with energy management, making it easy to install and compatible with all Type-2 EVs. Regular over-the-air updates ensure that the charger remains future-proof. Whether used as a standalone unit or integrated with Enphase Energy Systems, users can seamlessly manage solar, battery, and EV charging through the Enphase App.

Save more with AI-driven home energy management, optimising for the lowest utility rates and efficient solar charging. Up to 100% of excess solar power can be directed to EV charging, maximising savings. Designed for all European grids, the IQ EV Charger 2 offers wired and wireless data connectivity for flexible installation. It also includes a built-in MID meter for accurate usage tracking and a Type-2 connector, suitable for all EVs in Europe. Access and control are managed easily through the Enphase App.

2. Integration with the Enphase Energy System

The IQ EV Charger 2 integrates flawlessly with Enphase Energy Systems, allowing users to manage solar, battery, and EV charging—all from the Enphase App. The following figures show the system diagram of a few configurations in which the charger can be installed.

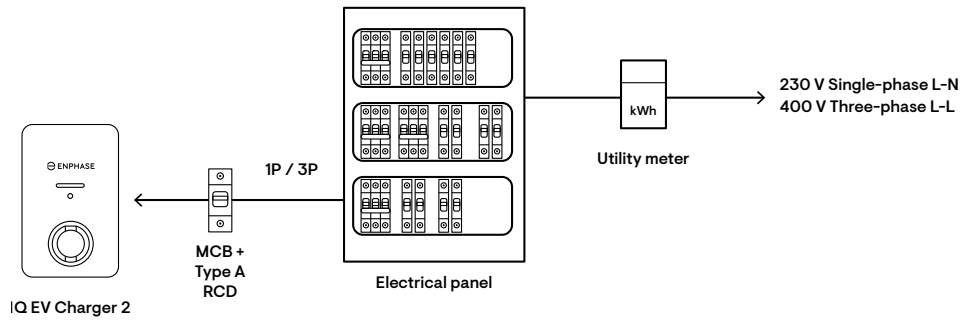

Figure 1: Standalone configuration

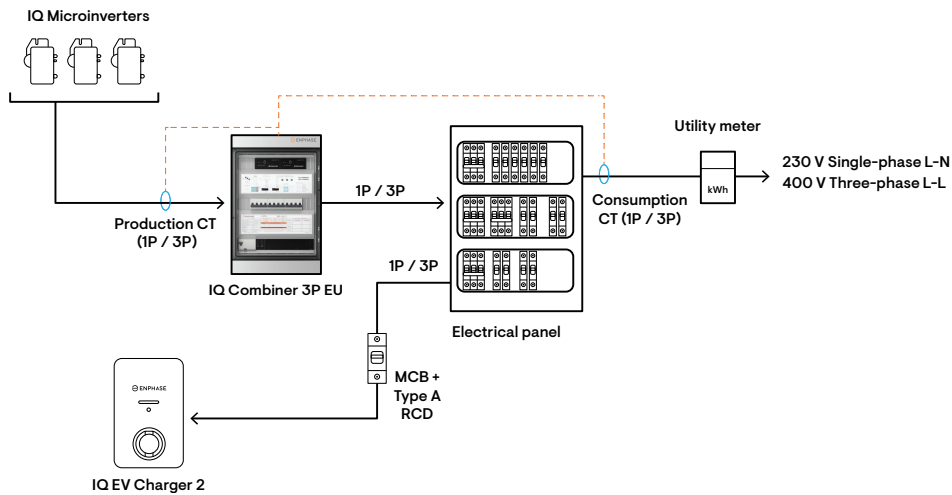

Figure 2: Integrated with an Enphase PV system configuration

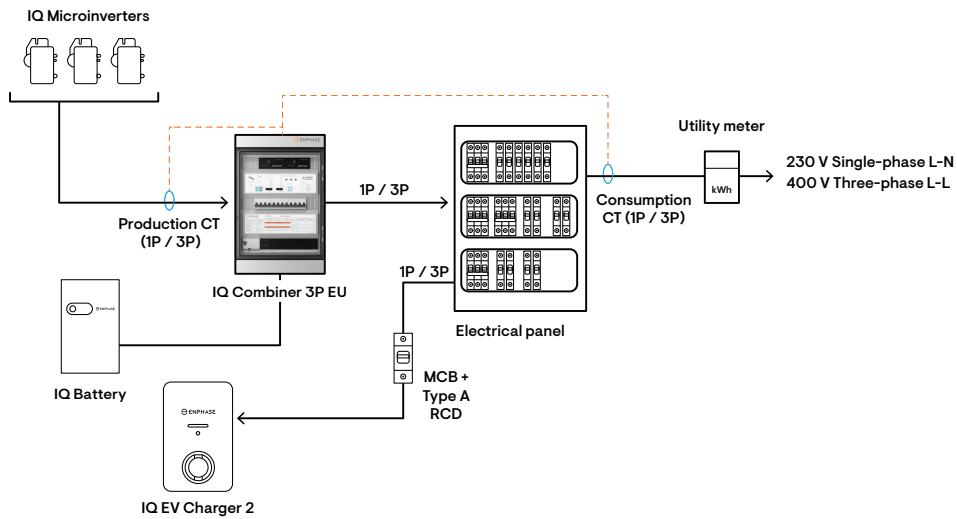

Figure 3: Integrated with an Enphase PV + Battery system configuration

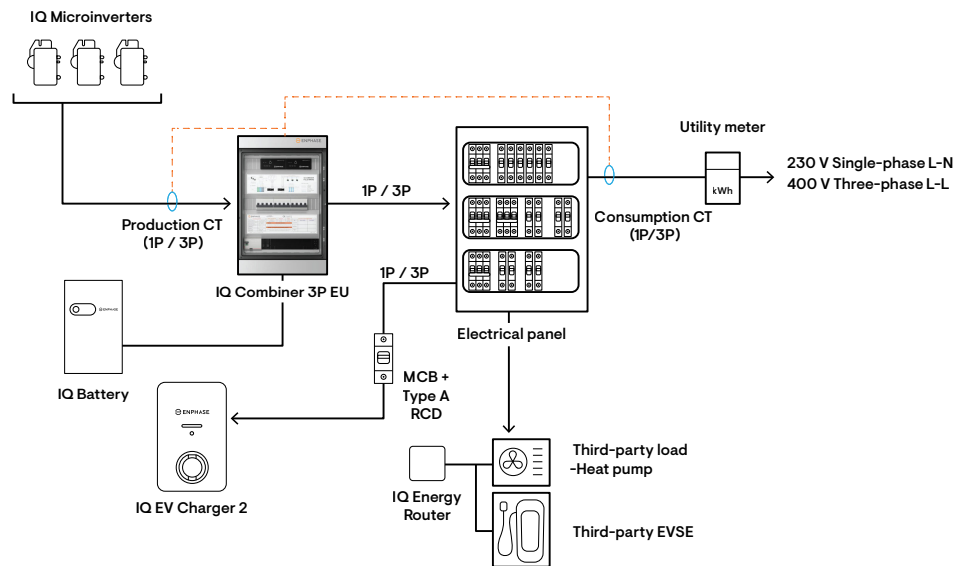



Figure 4: Integrated with an Enphase PV + Battery system + HEMS configuration

 **NOTE:** The Integrated with an Enphase PV + Battery system + HEMS configuration is supported by Enphase only in a limited number of countries.

For more information on each of the supported CT configurations, see the [IQ EV Charger 2 installation configurations technical brief](#).

3. Pre-installation checklist

Location considerations:

- Install the charger on any flat, vertical surface (wood, concrete, or single vertical stud) that supports its weight. The surface should be smooth with minimal irregularities and an incline of less than 5°.
- Mount the charger between 800 mm and 1200 mm above the floor level.
- For the tethered model, ensure the 7,5 m cable can comfortably reach the vehicle inlet (or socket). A 7,5 m cable is also available for purchase with the socketed model and can be purchased separately from the Enphase Store or from your distributor. To achieve the proper charging speed with your socketed model, use a cable that matches your charger's power rating.
- A Type-2 connector holster is included with the tethered model and is available with the socketed model. Install it near the charger to stow the cable and protect the connector.
- Ensure a stable internet connection through Wi-Fi or Ethernet to enable smart features.

Hardware considerations:

- Wiring from the circuit breaker supplying the IQ EV Charger 2 complies with IEC 60364 and local standards.
- Install the charger in one of the following ways:

- A dedicated 30 mA Type A RCD/RCCB (10 kA max. short-circuit rating) along with an MCB (Type C tripping characteristics, rated for 125% of the maximum charging station current). For example, a 20 A circuit breaker is recommended for a 16 A charging current setting.
- An RCBO with Type A RCD characteristics (30 mA max. tripping sensitivity) and Type C tripping characteristics (rated for 125% of the maximum charging station current). For example, a 20 A circuit breaker is recommended for a 16 A charging current setting.
- The charger has an integrated ± 6 mA RDC-DD for DC leakage protection in line with IEC 61851-1:2019 Cl. 8.5.
- The installation of the charger, including the RCD/MCB/RCBO, must comply with IEC 60364 and local regulations.

Other considerations:

- For information on the supported configurations, see the [IQ EV Charger 2 installation configurations technical brief](#).
- Hardware upgrades are recommended to leverage all smart features at the existing Enphase sites.
- Ensure Production and Consumption CTs are installed correctly at PV-only sites for monitoring solar production and total home load. Ensure that all CTs are properly located and installed according to the [IQ EV Charger 2 installation configurations technical brief](#).

4. What's in the box

4.1 Tethered Type-2 model

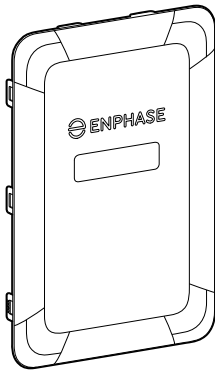

Aesthetic cover × 1

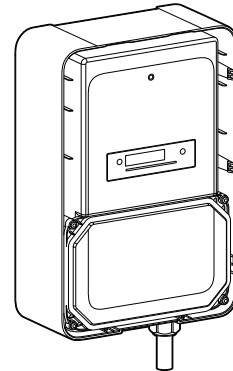

IQ EV Charger 2 enclosure × 1

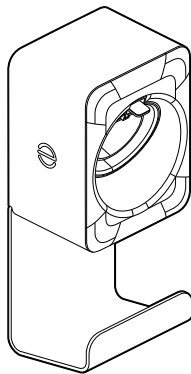

Type-2 connector holster and cable tidy × 1

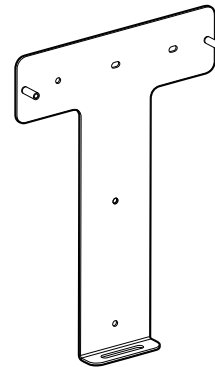

Mounting bracket × 1

An accessories box that includes the following items:

- Tx25 x 50 chipboard screws × 8
- Expansion plugs × 8
- Tx25 x 60 chipboard screws × 2
- M32 cable gland × 1
- M25 cable gland × 1
- M32/M25 gland reducer × 1
- Sealing inserts and blanking plugs

4.2 Socketed Type-2 model

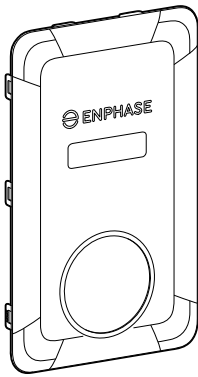

Aesthetic cover × 1

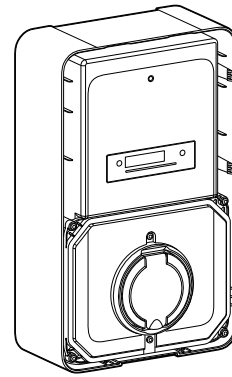

IQ EV Charger 2 enclosure × 1

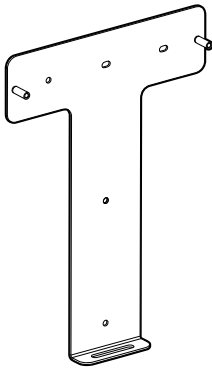

Mounting bracket × 1

An accessories box that includes the following items:

- Tx25 x 50 chipboard screws × 4
- Expansion plugs × 4
- Tx25 x 60 chipboard screws × 2
- M32 cable gland × 1
- M25 cable gland × 1
- M32/M25 gland reducer × 1
- Sealing inserts and blanking plugs

☑ **NOTE:** The socketed model does not include a Type-2 connector holster and cable tidy kit or a Type-2 to Type-2 charging cable. These items can be acquired separately from the Enphase Store or through your distributor.

5. Tools/Additional items required

The following tools/items are provided by the installer:

- Spirit level
- Pencil
- Tape measure
- Power drill
- Power tool
- Tx25 bit
- Tx20 bit
- Tx10 bit
- 4 mm flathead screwdriver

- Wrench
- Multimeter
- Wire stripper
- Crimping tool

6. Mounting the wall bracket

IQ EV Charger 2 can be mounted on a variety of surfaces.

- [Mounting on a timber or concrete wall](#) on page 9
- [Mounting on a single vertical timber stud](#) on page 10

6.1 Mounting on a timber or concrete wall

To mount on a wood or concrete wall, follow these steps:

1. Starting at the installation position closest to the power source, mark a level line on the wall as a guide.
2. Using the mounting bracket as a template, mark out three drilling holes.

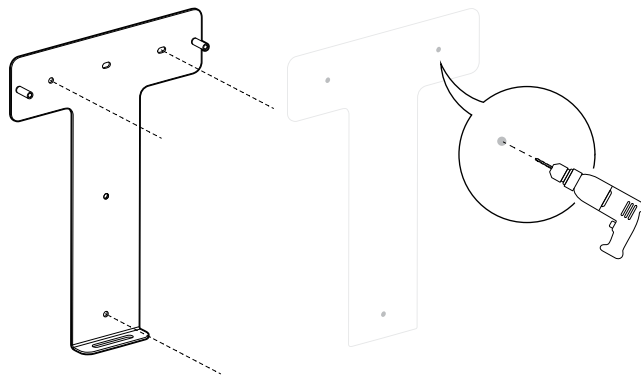

3. Drill to a minimum depth of 55 mm using an 8 mm diameter drill bit.



WARNING: Multiple risks. Do not drill into or attach to electric wiring or pipes in the wall.

4. Mount the wall bracket to the wall using the provided screws.

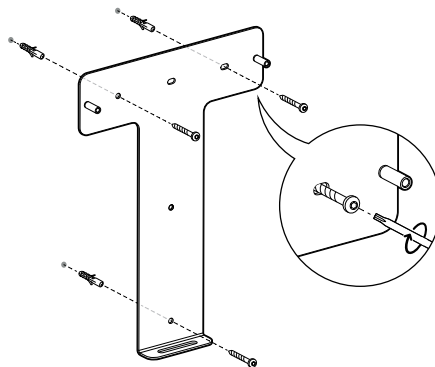

NOTE: Expansion plugs must be inserted into the hole before threading screws on the wooden wall.

6.2 Mounting on a single vertical timber stud

To mount on a single vertical timber stud, follow these steps:

1. Starting at the installation position closest to the power source, mark a level line on the wall as a guide.
2. Using the mounting bracket as a template, mark out three drilling holes.

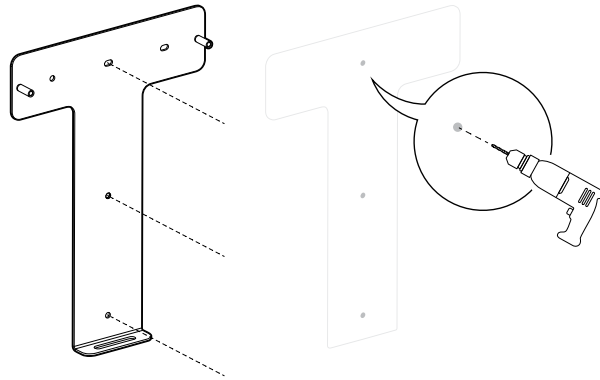

3. Drill to a minimum depth of 55 mm using an 8 mm diameter drill bit.

 **WARNING:** Multiple risks. Do not drill into or attach to electric wiring or pipes in the wall.

4. Mount the wall bracket to the wall using the provided screws.

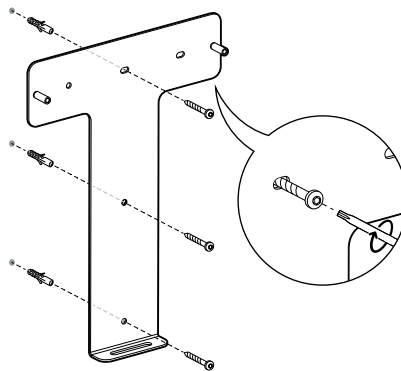

7. Wall-mounting the IQ EV Charger 2

1. Lift and position the IQ EV Charger 2 next to the wall bracket.

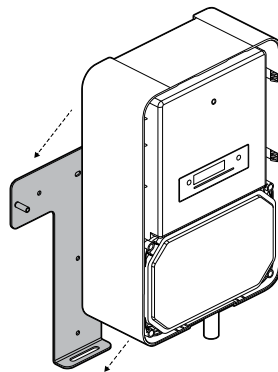

2. Secure the bottom of the charger by inserting the mounting guide protrusion at the bottom of the IQ EV Charger 2 into the corresponding socket on the base of the wall bracket.

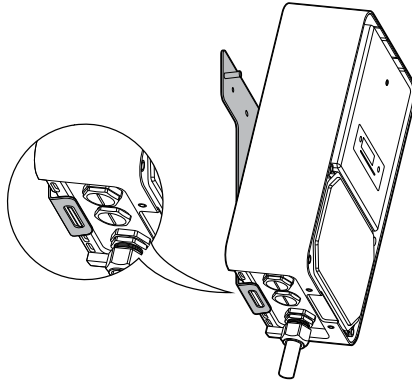

3. Insert the charger into the wall bracket. Carefully align the prongs on the left and right sides of the wall bracket with the corresponding gaps on the back of the charger enclosure. Slide the prongs through the gaps until the charger is securely in place.

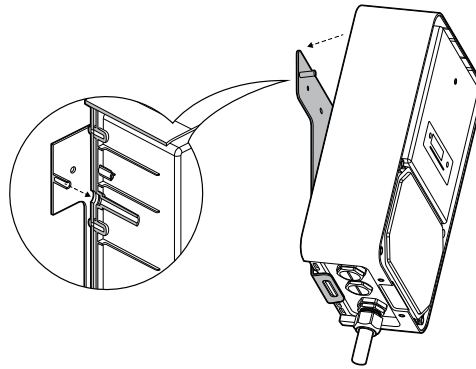

4. Fix the charging station onto the wall bracket using the screws provided—torque to 7 N m.

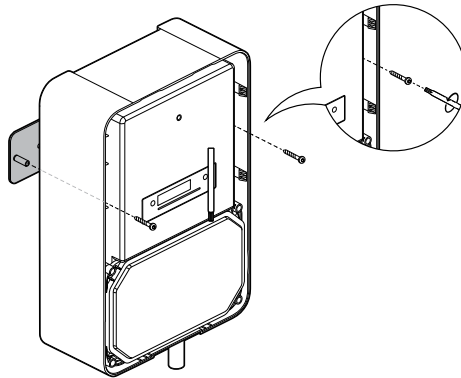

8. Mounting the connector holster

A Type-2 connector holster is included with the tethered model to keep the charging cable organised and accessible. For the socketed model, it can be purchased separately to enhance cable management and protection.

1. Mark a level line on the wall as a guide. Use the holster as a template to mark out drilling holes in the wall.

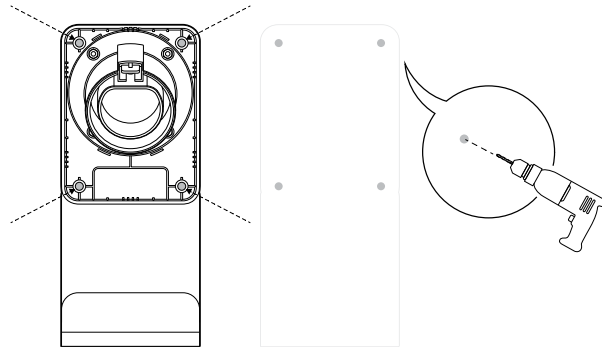

2. Drill to a minimum depth of 55 mm using an 8 mm diameter drill bit.



WARNING: Multiple risks. Do not drill into or attach to electrical wiring or pipes in the wall.

3. Mount the holster to the wall using the provided screws.

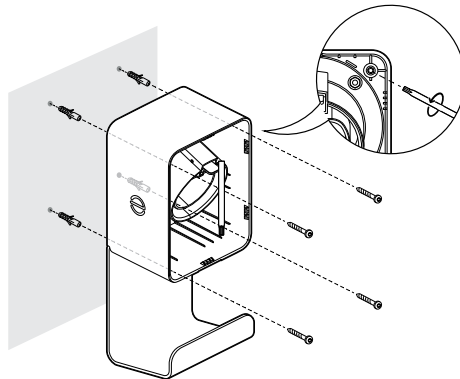

NOTE: Expansion plugs must be inserted into the hole before threading screws on the wooden wall.

4. Close the holster with the aesthetic cover.

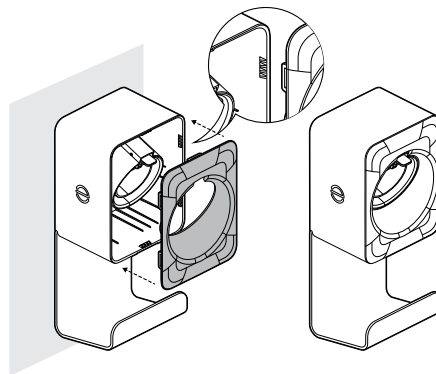

9. Power supply wiring

The IQ EV Charger 2 has both a tethered and socketed model. Based on the model, see one of the following topics:

- [Supply wiring for tethered Type-2 model](#) on page 13
- [Supply wiring for socketed Type-2 model](#) on page 15

9.1 Supply wiring for tethered Type-2 model

9.1.1 Preparation

Access the service panel by removing the four corner screws.

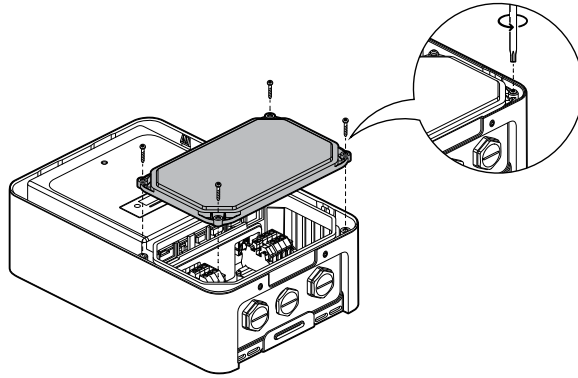

Supply wiring may be routed through two openings in the product. Based on whether the supply wiring will be routed through the rear or the bottom, see one of the following topics:

- [Supply wiring through the rear cable entry](#) on page 13
- [Supply wiring through the bottom cable entry](#) on page 14

9.1.2 Supply wiring through the rear cable entry

Pierce the sealing grommet with input cables from the rear of the IQ EV Charger 2 and terminate the conductors.

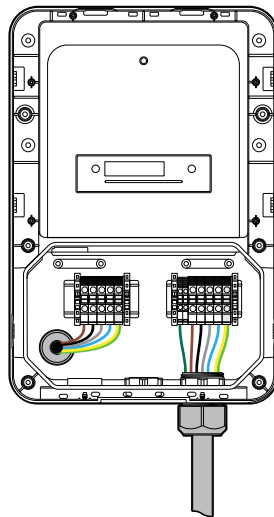

- ✓ **NOTE:** The unused cable entry in the middle can be used for Ethernet communication. For more information, see [Wiring connections for communication](#) on page 20.
- ✓ **NOTE:** Torque screws on the terminal block to 1.5 N m.
- ✓ **NOTE:** Check the torque of all electrical connections, including the factory-made terminations because they may loosen during transportation.
- ✓ **NOTE:** To learn how to connect the IQ EV Charger 2 to suit your grid supply and earthing arrangement, see [Phase wiring diagrams for grid supply types](#) on page 18.
- ⚠ **WARNING:** Ensure the charger is installed using protective devices of the appropriate rating. For more information, see the [Pre-installation checklist](#) on page 6.

9.1.3 Supply wiring through the bottom cable entry

1. Replace the plug on the input side with the provided M32 cable gland. Torque this gland to 11.3 N m.

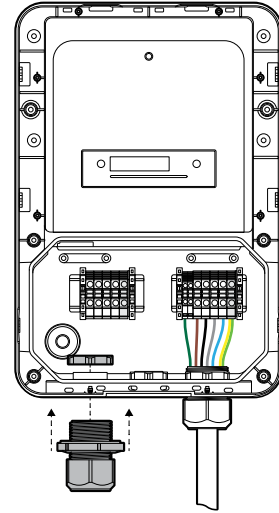
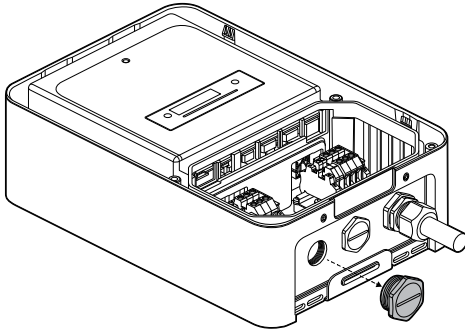

If the charger is being installed in a single-phase configuration, the provided cable gland and M32/M25 reducer can be used instead of the M32 cable gland.

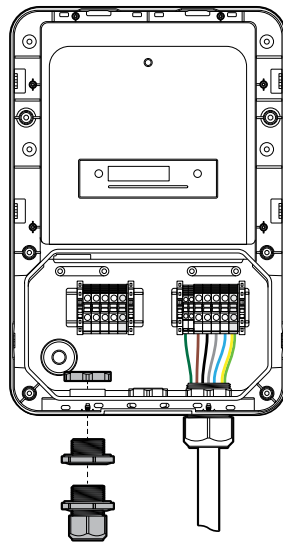

2. Run the power supply wiring through the M32 cable gland and terminate the conductors.

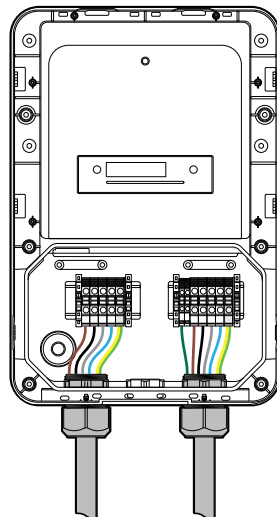

- ✓ **NOTE:** The unused cable entry in the middle can be used for Ethernet communication. For more information, see [Wiring connections for communication](#) on page 20.
- ✓ **NOTE:** Torque screws on the terminal block to 1.5 N m.
- ✓ **NOTE:** Check the torque of all electrical connections, including the factory-made terminations because they may loosen during transportation.
- ✓ **NOTE:** To learn how to connect the IQ EV Charger 2 to suit your grid supply and earthing arrangement, see [Phase wiring diagrams for grid supply types](#) on page 18.
- ⚠ **WARNING:** Ensure the charger is installed using protective devices of the appropriate rating. For more information, see the [Pre-installation checklist](#) on page 6.

9.1.4 Completing supply wiring

Close the service panel using the four provided corner screws. Torque the screws to 1.8 N m.

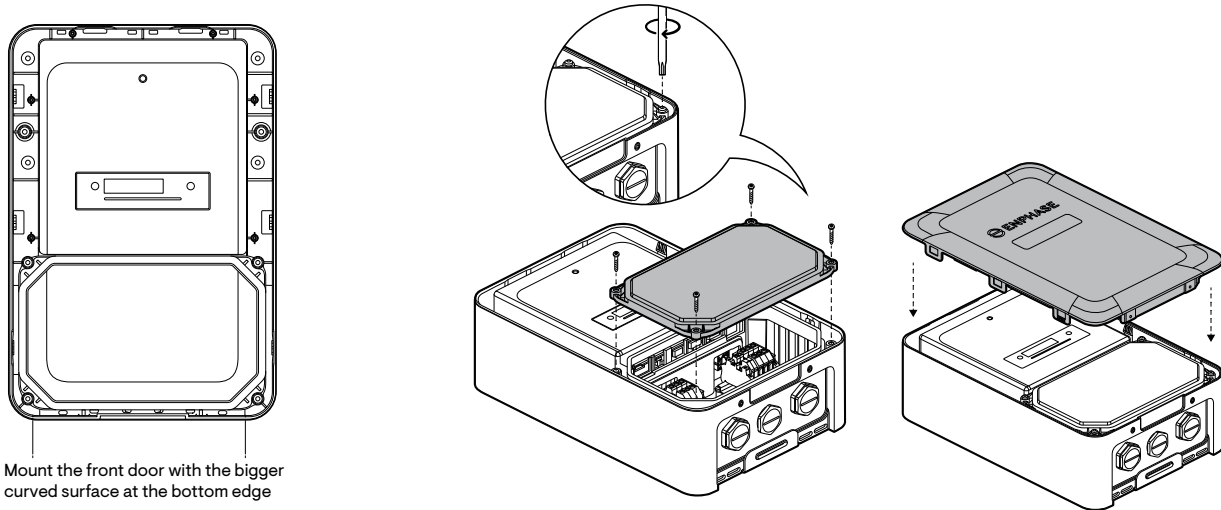

9.2 Supply wiring for socketed Type-2 model

9.2.1 Preparation

Access the service panel by removing the four corner screws and two inner screws next to the socket.

- ✓ **NOTE:** The two screws above and below the socket are longer relative to the four corner screws on the service panel.

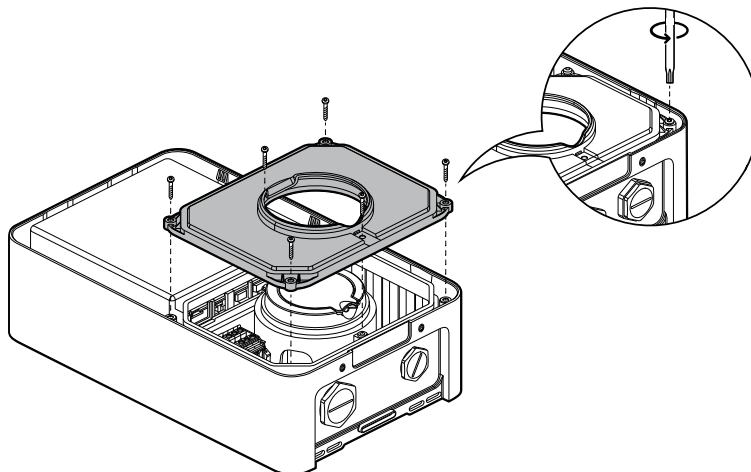

Supply wiring may be routed through two openings in the product. Based on whether the supply wiring will be routed through the rear or the bottom, see one of the following topics:

- [Supply wiring through the rear cable entry](#) on page 16
- [Supply wiring through the bottom cable entry](#) on page 16

9.2.2 Supply wiring through the rear cable entry

Pierce the sealing grommet with input cables from the rear of the IQ EV Charger 2 and terminate the conductors.

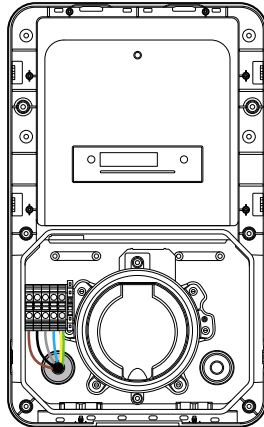

- ✓ **NOTE:** The unused cable entry in the middle can be used for Ethernet communication. For more information, see [Wiring connections for communication](#) on page 20.
- ✓ **NOTE:** Torque screws on the terminal block to 1.5 N m.
- ✓ **NOTE:** Check the torque of all electrical connections, including the factory-made terminations because they may loosen during transportation.
- ✓ **NOTE:** To learn how to connect the IQ EV Charger 2 to suit your grid supply and earthing arrangement, see [Phase wiring diagrams for grid supply types](#) on page 18.
- ⚠ **WARNING:** Ensure the charger is installed using protective devices of the appropriate rating. For more information, see the [Pre-installation checklist](#) on page 6.

9.2.3 Supply wiring through the bottom cable entry

1. Replace the plug on the input side with the provided M32 cable gland. Torque this gland to 11.3 N m.

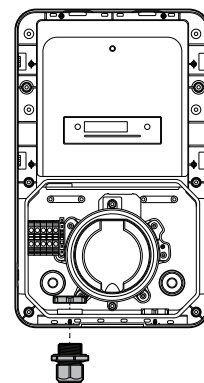
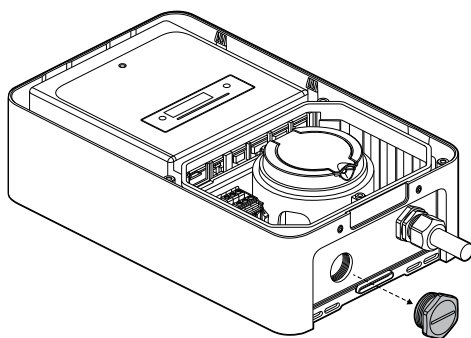



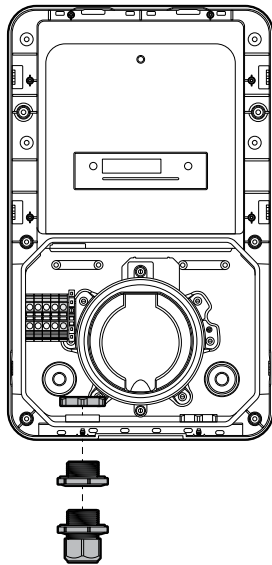

If the charger is being installed in a single-phase configuration, the provided cable gland and M32/M25 reducer can be used instead of the M32 cable gland.

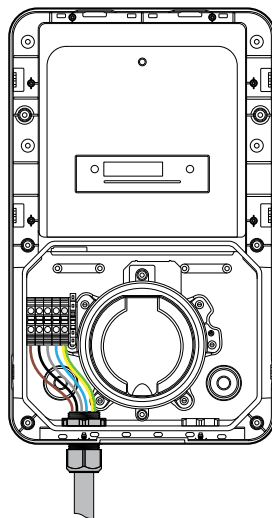

2. Run the power supply wiring through the M32 gland and terminate the conductors.



- 
NOTE: The unused cable entry in the middle can be used for Ethernet communication. For more information, see [Wiring connections for communication](#) on page 20.
- 
NOTE: Torque screws on the terminal block to 1.5 N m.
- 
NOTE: Check the torque of all electrical connections, including the factory-made terminations because they may loosen during transportation.
- 
NOTE: To learn how to connect the IQ EV Charger 2 to suit your grid supply and earthing arrangement, see [Phase wiring diagrams for grid supply types](#) on page 18.
- 
WARNING: Ensure the charger is installed using protective devices of the appropriate rating. For more information, see the [Pre-installation checklist](#) on page 6.

9.2.4 Completing the supply wiring

Close the service panel using the four corner screws and two inner screws. Torque the screws to 1.8 N m.

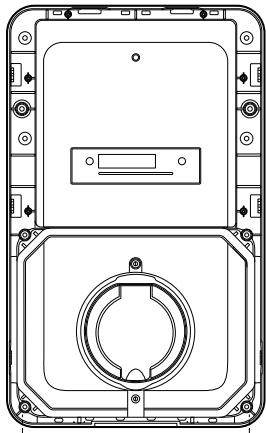

Mount the front door with the bigger curved surface at the bottom edge

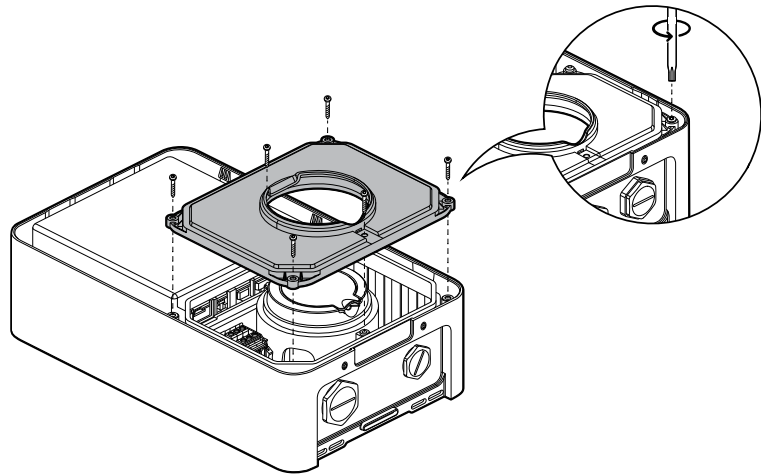

9.3 Phase wiring diagrams for grid supply types

The IQ EV Charger 2 must be wired appropriately according to the earthing arrangement of the grid supply and the number of phases connected to the charger. Determine the configuration in which the charger will be installed and refer to the appropriate diagram.

- [Grid supply with a TN or TT earthing \(with neutral\)](#) on page 18
- [Grid supply with an IT earthing \(without neutral\)](#) on page 20

9.3.1 Grid supply with a TN or TT earthing (with neutral)

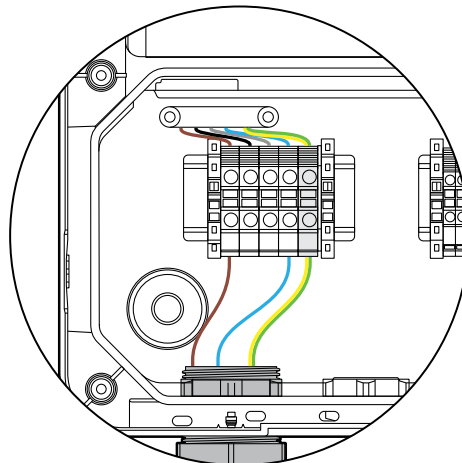

Figure 5: Wiring diagram of single-phase with Neutral

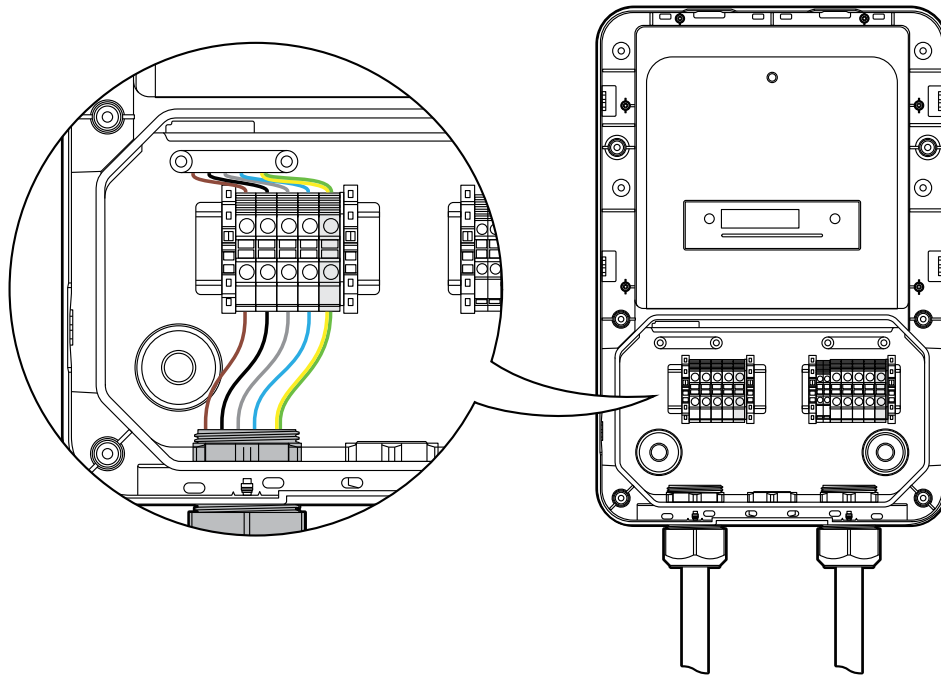
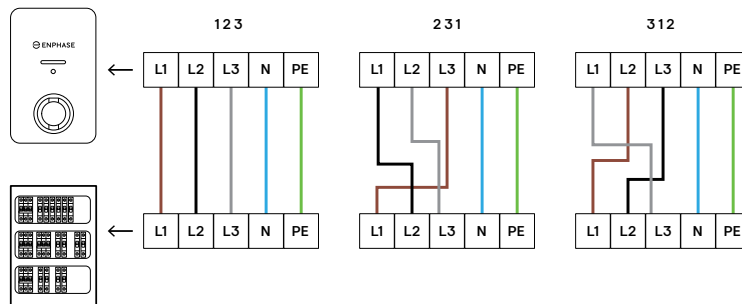

Figure 6: Wiring diagram of three-phase with Neutral

✔ **NOTE:** For three-phase installations with an IQ Gateway, ensure that the phase connected to the L1 terminal of the IQ EV Charger 2 matches the L1 phase of the IQ Gateway Metered.

Phase rotation is recommended for three-phase installations with multiple EV charging points, especially when vehicles that only charge on L1 are involved. This helps to avoid overloading L1. Additionally, capturing phase rotation information during the activation process (see [Activating the IQ EV Charger 2](#) on page 23) is important to ensure accurate consolidation of consumption data.

The following figure shows the recommended phase rotation.



9.3.2 Grid supply with an IT earthing (without neutral)

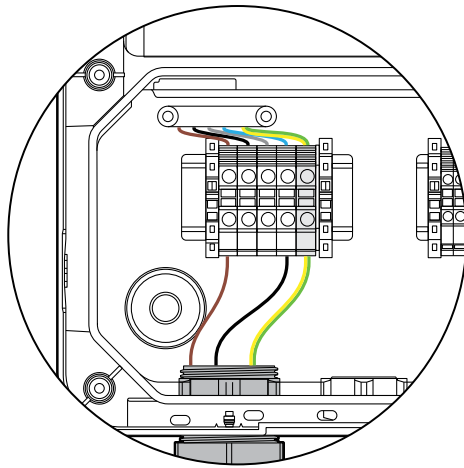

Figure 7: Wiring diagram of two-phase without Neutral

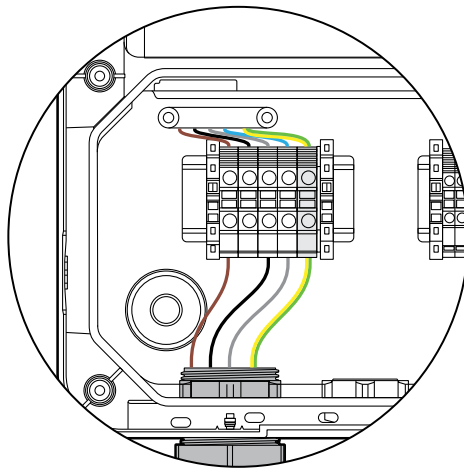
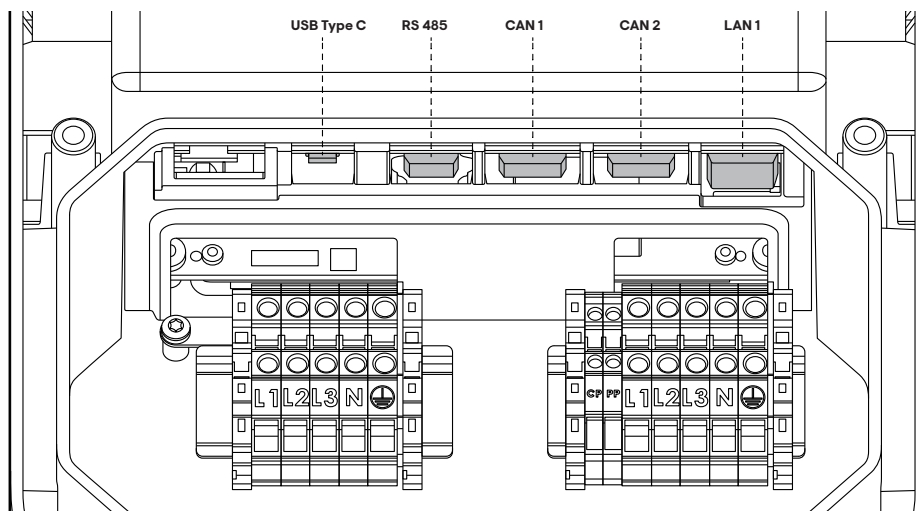

Figure 8: Wiring diagram of three-phase without Neutral

10. Wiring connections for communication

The IQ EV Charger 2 hardware supports several forms of wired communication, as shown in the following figure.



✓ **NOTE:** CAN support will not be available at the launch.

10.1 Communication cable wiring through the rear cable entry

10.1.1 Tethered Type-2 model

Pierce the sealing grommet with Ethernet cables from the rear of the IQ EV Charger 2, then terminate the conductors.

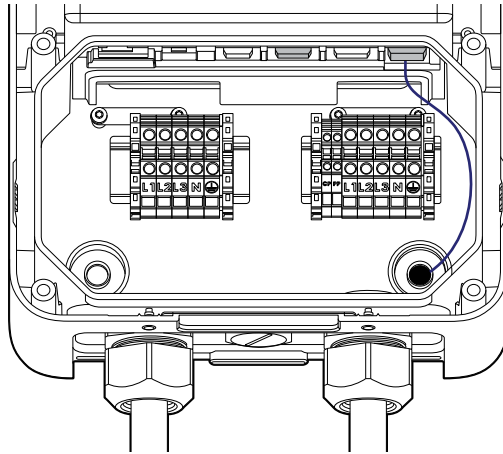

10.1.2 Socketed Type-2 model

Pierce the sealing grommet at the bottom right with Ethernet cables from the rear of the IQ EV Charger 2, then terminate the conductors.

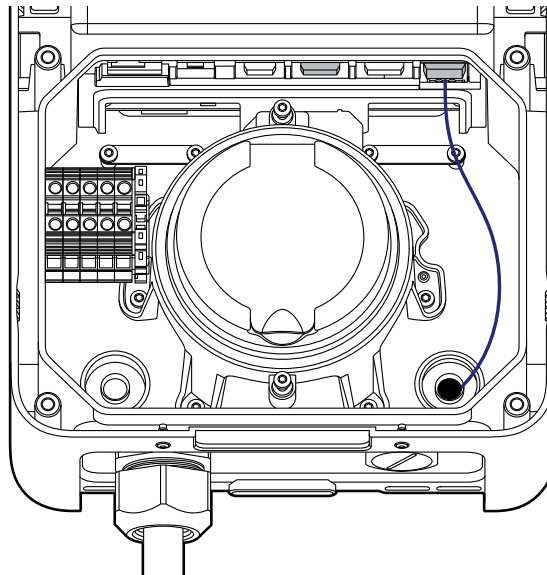

10.2 Communication cable wiring through the bottom entry

10.2.1 Tethered Type-2 model

1. Replace the plug at the bottom with the provided M25 cable gland and sealing insert. Torque the gland to 9 N m.

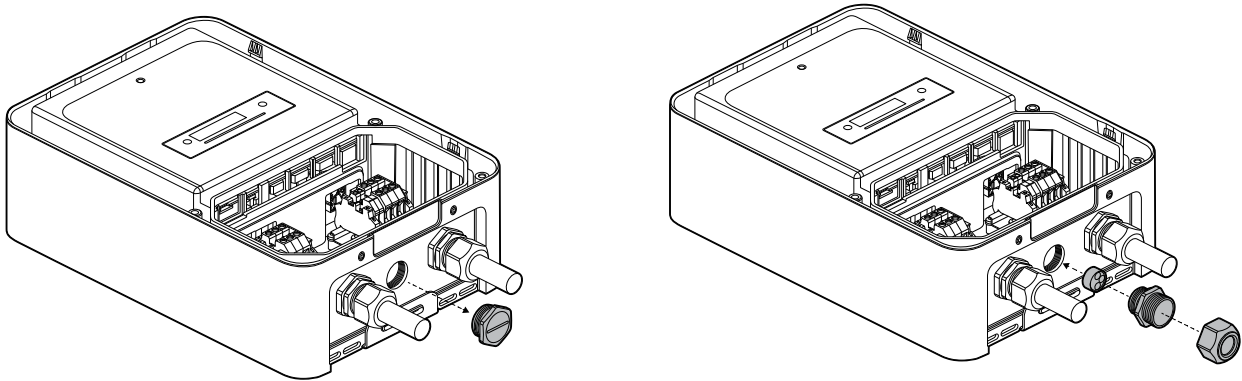

2. Run the Ethernet cable through the holes in the sealing insert and M25 cable gland, then connect it to the respective connectors, as shown in the following figure.

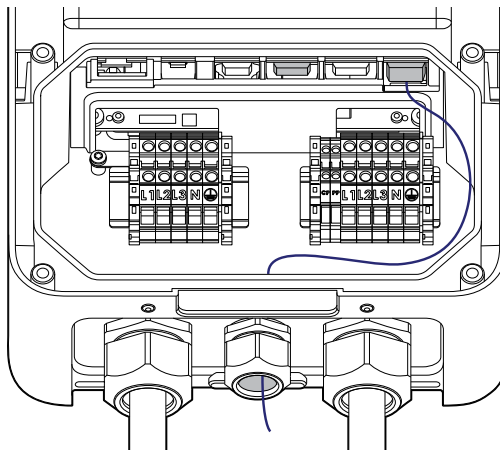

Sealing inserts are provided with 2- and 3-hole configurations. Choose the appropriate sealing inserts based on installation requirements. The inserts come with blanking plugs; keep the blanking plugs in the unused holes of the sealing inserts as shown in the following figure.

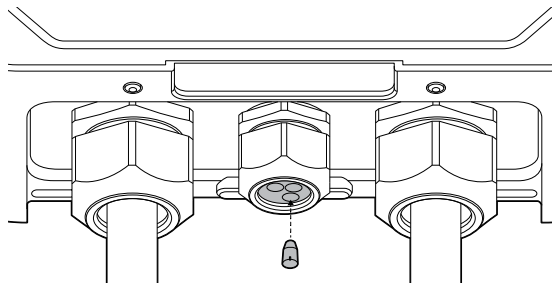

10.2.2 Socketed Type-2 model

1. Replace the plug at the bottom with the provided M25 cable gland and sealing insert. Torque the gland to 9 N m.

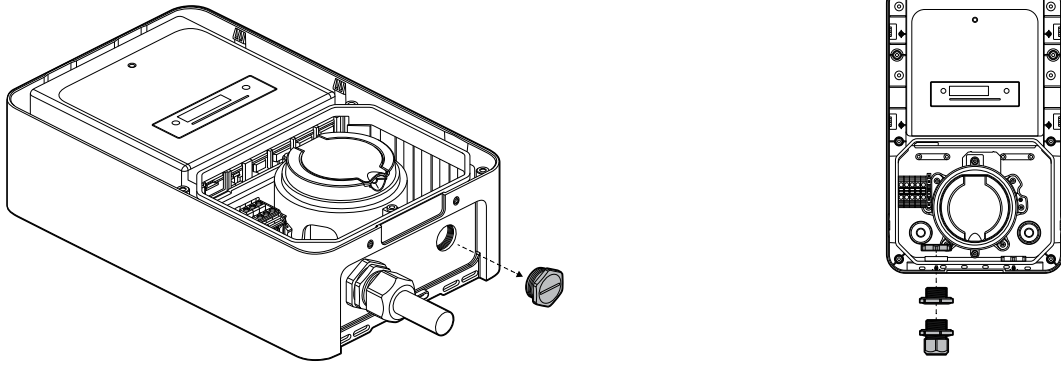

2. Run the Ethernet cable through the holes in the sealing insert and M25 cable gland, then connect it to the respective connectors, as shown in the following figure.

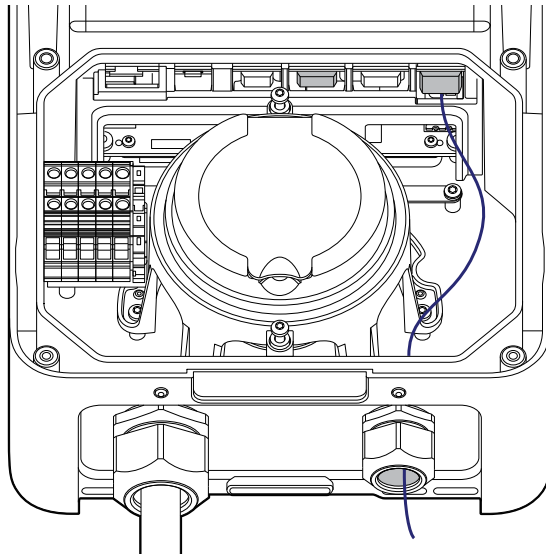

Sealing inserts are provided with 2- and 3-hole configurations. Choose the appropriate sealing inserts based on installation requirements. The inserts come with blanking plugs; keep the blanking plugs in the unused holes of the sealing inserts as shown in the following figure.

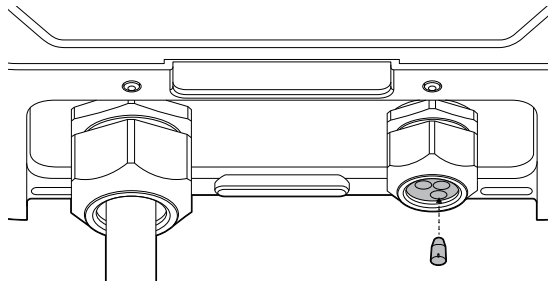

11. Activating the IQ EV Charger 2

The IQ EV Charger 2 can be activated (commissioned) through the Enphase Installer App or the Enphase App. Activating the charger unlocks its smart features, including dynamic power adjustment to prevent overloading the main supply, AI-based optimisation for

charging when electricity rates are lowest, and access control to prevent unauthorized usage. You can use the IQ EV Charger 2 without activation, though doing so limits its smart features.

The device requires internet access through Ethernet or Wi-Fi (configured during activation) to complete the activation.

11.1 Activation through the Enphase Installer App

✔ **NOTE:** The Enphase Installer App is available primarily for Enphase-certified installers who have completed the Enphase training. If you want to become an Enphase-certified installer and join our network, visit <https://enphase.com/installers/training/getting-started>.

1. Download the version 4.4.0 Enphase Installer App from the App Store or Google Play.
2. Log into your installer account using the account details.
3. Ensure that the white LED on the charger is illuminated before beginning the commissioning process.
4. Follow the on-screen instructions and refer to the FAQs for further assistance in completing the activation.

11.2 Activation through the Enphase App

✔ **NOTE:** The activation process involves technically intensive installation details that should only be addressed by a competent electrician. The homeowner must collaborate with the electrician to correctly complete the activation and setup process to ensure safe and correct operation. For more information see, the [IQ EV Charger 2 commissioning guide for electricians and homeowners](#).

1. Download the version 4.0 Enphase App from the App Store or Google Play.
2. Have the homeowner create an account or log into an existing Enphase Account with their account details.
3. Ensure that the white LED on the charger is illuminated before beginning the commissioning process.
4. Follow the on-screen instructions and refer to the FAQs for further assistance in completing the activation.

12. Finishing the installation

1. After the activation of the charger, snap the aesthetic cover onto the front of the enclosure.
2. Secure the cover onto the enclosure at the bottom of the unit using the two provided M3 screws—torque to 0.6 N m.

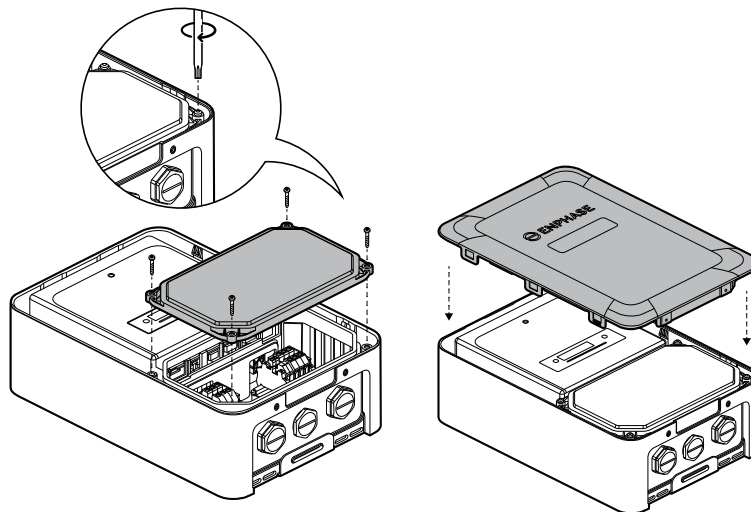

13. Post-installation checklist

- The device will display a **green LED indicator** after commissioning is complete. If the device has not been activated, the LED will remain **white**.
- Ensure that any unused cable entry points are sealed with the provided plugs to maintain weather integrity.

✔ **NOTE:** This charger contains tamper-proof labels and sealed electronics. Any tampering or removal of these labels or seals will void the product's warranty.

- The socketed model is equipped with a **Type-2 shuttered socket** to prevent accidental contact with live terminals. The shuttered socket opens by applying slight pressure when inserting the Type-2 plug. The notch on the front of the connector aligns with the socket, ensuring a secure connection.

- Ensure the connector is fully inserted into the socket. Some friction may be encountered, and additional pressure might be required to ensure a complete connection.



 **NOTE:** When properly connected, the Enphase logo on the connector should sit flush against the surface of the shuttered socket.

- The LED bar will change from static green to blue when the charger detects that the electric vehicle (EV) is correctly connected. If the EV is not correctly connected, the LED remains static green or white.

14. Troubleshooting

14.1 MID meter display

The IQ EV Charger 2 includes an integrated MID meter and display. Upon power-up, the device shows the MID firmware version and CRC, as required for MID compliance, followed by the charger's lifetime energy consumption—each displayed for 5 seconds before the screen goes blank. The display reactivates during an ongoing charging session, showing values in the following sequence.

Display value	Voltage (per phase)	Current (per phase)	Power (total)	Session energy
Duration	2 seconds	2 seconds	2 seconds	9 seconds

14.2 LED pattern of an uncommissioned device

LED color	LED sequence	Device status
Green	Laser pattern—left to right	Powering on
White	Static ON	No EV is connected
Blue	Static ON	Ready to charge, not currently charging
Blue	Fading in and out	EV charging in progress
Red	All LEDs indefinitely blinking ON/OFF	Fault/Error

14.3 LED pattern of an activated device

LED color	LED sequence	Device status
Green	Static ON	No EV connected
Green	First, middle, and last LED ON	Locked
White	Static ON	Network connectivity lost
Yellow	Boomerang—left to right, right to left	Activation in progress
Green	Static ON for 5 seconds	Activation/Update successful
Red	Blinking ON/OFF for 5 seconds	Activation/Update failed
Purple	Laser pattern—left to right	OTA update in progress
Green	Boomerang—left to right, right to left	Waiting for authorisation
Blue	Static ON	Ready to charge, not currently charging
Blue	Fading in and out	EV charging in progress

LED color	LED sequence	Device status
Green	Droplet pattern from the middle outwards	Charging authorised but the device is not ready to charge
Red	All LEDs indefinitely blinking ON/OFF	Fault/Error

15. Accessories

Enphase offers various accessories compatible with the IQ EV Charger 2, available for purchase at enphase.com.

SKU	Description
TYPE2-CABLE-7.5M-32A-3P-SOCKET	Three-phase, 32 A, Type-2 connector cable for socketed IQ EV Charger 2
TYPE2-CABLE-7.5M-32A-3P-WIRED	Three-phase, 32 A, Type-2 connector cable for tethered IQ EV Charger 2
TYPE2-CABLE-7.5M-32A-1P - WIRED	Single-phase, 32 A, Type-2 connector cable for tethered IQ EV Charger 2
TYPE2-CONN-HOLSTER-EN	Enphase Type-2 connector holster with integrated cable management
IQ-EVSE-EU-INSTALL-KIT	Kit with all hardware required for installation of IQ EV Charger 2

16. Specifications

	IQ-EVSE-EU-3032-0005-1300	IQ-EVSE-EU-3032-0105-1300
Model name	IQ EV Charger 2 (socketed, three-phase/single-phase)	IQ EV Charger 2 (tethered, three-phase/single-phase)

Electrical specifications				
Nominal voltage ($\pm 10\%$)	400 V	230 V	400 V	230 V
	3 x 230 V		3 x 230 V	
Nominal frequency	50 Hz			
Maximum charging power	22 kW (three-phase Wye)	7.4 kW (single-phase Wye)	22 kW (three-phase Wye)	7.4 kW (single-phase Wye)
	12.7 kW (three-phase Delta)		12.7 kW (three-phase Delta)	
Earthing arrangement	TN, TT, or IT			
Rated output current	32 A per phase			
Provided cable gland size	M32 gland	M25 gland	M32 gland	M25 gland
	(15–25, 4 mm)	(11–17,9 mm)	(15–25,4 mm)	(11–17,9 mm)
Socket or connector	Type-2 shuttered socket		7,5 m Type-2 connector cable	

Mechanical specifications		
Enclosure dimensions (L x W x D)	410 mm x 250 mm x 128 mm	370 mm x 250 mm x 118 mm
Weight	6 kg	11 kg (including the charging cable)
Enclosure rating	IP55/IK10	
Supply cable entry options	Bottom or rear cable entry	

Environmental specifications	
Humidity rating	5% to 95% (condensing)
Altitude	<2500 m
Operating temperature	-40°C to 55°C

Environmental specifications

Storage temperature	-40°C to 80°C
---------------------	---------------

Communication options

Wireless network	2.4/5GHz Wi-Fi (802.11 ax)
Bluetooth	BT/BLE 5.3
Wired communication	Ethernet, RS-485, CAN
ISO15118	Yes (hardware ready)

Safety and compliance

Certification	CE (LVD EU/2014/35, EMC Directive EU/2014/30, RED EU/2014/53, RoHS3.0, REACH, IEC/EN 61851-1, IEC/EN 61851-21-2, IEC/EN 62196-1, IEC/EN 62955, IEC 61439-7, IEC/EN 60364-4-41), MID (EN 50470-1, EN 50470-3), EV Ready 2.0
Safety features	Overvoltage protection (253 V), RDC-DD (± 6 mA), relay weld detection, overcurrent detection (+20%)
In-built sensors	Ambient light sensor, temperature sensor, humidity sensor, and tilt sensor
Metering accuracy	$\pm 1\%$ (Class-B, MID-certified)

Features

LED indicator	Animated line LED with RGB colors to indicate the state of the IQ EV Charger 2
MID meter display	Display voltage, current, and energy (kWh) consumption of the EV charger
Smart scheduling	Optimises charging with dynamic tariff rates and excess solar power
Self-consumption	Charge EV on clean energy from the sun by using excess solar power with an Enphase Energy System
Automatic phase-switching	Automatically switches between three-phase and single-phase to optimise charging from excess PV
Access control	Available via the Enphase App RFID/NFC – Hardware ready
Integration support	OCPP 2.0.1 and APIs

Warranty

Warranty duration	5 years
-------------------	---------

17. Safety information

IMPORTANT SAFETY INFORMATION. KEEP THIS DOCUMENT FOR FUTURE REFERENCE.

This guide contains important instructions you must follow during the installation and maintenance of the Enphase IQ EV Charger 2. Failing to follow any of these instructions may void the warranty (<https://enphase.com/warranty>).

Safety and advisory symbols



DANGER: This indicates a hazardous situation, which, if not avoided, will result in death or serious injury.



WARNING: This indicates a situation where failure to follow instructions may be a safety hazard or cause equipment malfunction. Use extreme caution and follow instructions carefully.



NOTE: This indicates information that is very important for optimal system operation. Follow instructions closely.















Safety instructions



DANGER: Risk of electric shock. Risk of fire. Do not attempt to repair or service the IQ EV Charger 2 alone. Only a certified electrician shall install, troubleshoot, or otherwise service the IQ EV Charger 2.



DANGER: Risk of electric shock. Do not use Enphase equipment in a manner not specified by the manufacturer or in the quick install guide (QIG). Doing so may cause death or injury to persons or damage to equipment.

-  **DANGER:** Risk of electric shock. Always de-energize the AC branch circuit during an emergency and/or before servicing the IQ EV Charger 2.
-  **DANGER:** Risk of electric shock. Do not place fingers or foreign objects inside the coupler end of the Type-2 connector.
-  **DANGER:** Risk of electric shock. Risk of fire. If using a converter accessory (adapter), ensure that it is appropriately rated and compatible with your EV and the IQ EV Charger 2.
-  **DANGER:** Risk of electric shock. Do not allow children to operate this device. Adult supervision is mandatory when children are in proximity to an IQ EV Charger 2 that is in use.
-  **WARNING:** Do not install or use the IQ EV Charger 2 or its components that have been damaged in any way.
-  **WARNING:** You must install the IQ EV Charger 2 only on a suitable wall or pedestal mount (Enphase accessory) using the provided mounting bracket.
-  **WARNING:** The IQ EV Charger 2 is intended only for charging electric vehicles that do not require ventilation while charging.
-  **WARNING:** Only use the IQ EV Charger 2 with electric vehicles that have an IEC 62196 Type-2 (Mennekes) charge port. Refer to the vehicle owner's manual to determine if the vehicle is equipped with the correct charge port.
-  **WARNING:** Ensure the charging cable is positioned so as not to be stepped on, tripped over, or subjected to damage or stress.
-  **WARNING:** This vehicle charger unit is intended only for charging electric vehicles not requiring ventilation during charging.
-  **WARNING:** DO NOT operate the IQ EV Charger 2 or attempt to use the Type-2 connector if it is physically open, cracked, frayed, or otherwise visibly damaged. Immediately contact Enphase Support for service, referring to the Enphase Support section in this manual.
-  **NOTE:** Perform installation and wiring, including protection against lightning and resulting voltage surges, following all applicable local electrical codes and standards.
-  **NOTE:** Install correctly rated overcurrent protection as part of the system installation.
-  **NOTE:** To ensure optimal reliability and to meet warranty requirements, the IQ EV Charger 2 must be installed and/or stored according to the instructions in this guide.

 **Disposal**

In accordance with European Directive 2002/96/EC on waste electrical and electronic equipment and its implementation in national law, used electrical devices must be collected separately and recycled in an environmentally responsible manner. Ensure that you return your used device to your dealer or obtain information regarding a local, authorised collection and disposal system. Failure to comply with this EU Directive may result in a negative impact on the government.

Instructions pertaining to the risk of fire or electric shock

- Use the electric vehicle (EV) charging point only with electric vehicles that have an IEC 62196 Type-2 (Mennekes) charge port. Refer to the vehicle owner's manual to determine if the vehicle is equipped with the correct charge port.
- Ensure the charging cable is positioned so as not to be stepped on, tripped over, or subjected to damage or stress.
- **DO NOT** operate the EV charging point or attempt to use the Type-2 connector if it is physically open, cracked, frayed, or otherwise visibly damaged. Immediately contact [Enphase Support](#) for service.
- **DO NOT** place fingers inside the coupler end of the Type-2 connector.
- If using a converter accessory (adaptor), ensure that it is appropriately rated and compatible with both your EV and this EV charging point.
- **DO NOT** allow children to operate this device. Adult supervision is mandatory when children are in proximity to an EV charging point that is in use.
- Using the EV charging point outside the conditions specified in this product's technical documentation may result in undesired consequences.
- **DO NOT** attempt to repair or service the EV charging point on your own. Only a qualified electrician is permitted to install, service, repair, or relocate the EV charging point.

Additional safety information

-  **WARNING:** Turn off the input power to the electric vehicle supply equipment (EVSE) at the circuit breaker panel before servicing or cleaning the unit.

Corporate headquarters contact information

Enphase Energy, Inc.
Het Zuiderkruis 65, 5215 MV 's-Hertogenbosch, The Netherlands
Ph: +31 852 082 305

To view the latest version of the product warranty, see <https://enphase.com/warranty>.

To view the latest version of the product user manual, scan the following QR code.



This documentation has undergone thorough review before being published and contains the most updated information at the time of release. Enphase Energy, Inc. reserves the right to make changes to this product without further notice. Changes or modifications to this product by other than an authorized service facility may void the product warranty. Enphase Energy, Inc. does not assume any liability for damage or defects, in the broadest sense, from or related to the use or interpretation of this document.

Revision history

Revision	Date	Description
140-00515-01	November 2024	Initial release.

Enphase Support: <https://enphase.com/contact/support>.

140-00515-01-EN-2024-11-26
Applicable regions: Europe

© 2024 Enphase Energy. All rights reserved. Enphase, the e and CC logos, IQ, and certain other marks listed at <https://enphase.com/trademark-usage-guidelines> are trademarks of Enphase Energy, Inc. in the U.S. and other countries. Data subject to change.

